

EFX-300-X0X-0XX0-X

Series Active IR Faucet

Description

Line powered, sensor activated, electronic, chrome plated die cast body, pedestal hand washing faucet for pre-tempered or hot and cold water operation.

Flow Rates

- 0.5 gpm/1.9 Lpm Multi-Lam Spray
- 1.5 gpm/5.7 Lpm Aerated Stream
- 1.5 gpm/5.7 Lpm Laminar Stream

Specifications

Line Powered, Sensor Activated, Electronic, Chrome Plated Die Cast Body, Hand Washing Faucet with the following features:

- Solenoid valve above deck
- One tool service
- All wetted components to be stainless steel, engineered thermoplastic, EPDM, and copper or copper alloy
- Solenoid housed in removable carrier that includes supply strainer
- Integral above deck water supply shut off
- Supply strainer serviceable from above deck
- Vandal resistant spray insert, key housed inside faucet body
- All electronics sealed to IP-67
- Gold plated electrical contacts
- Above deck individual diagnostic indicators for battery life, solenoid condition, and power-up mode
- Flexible, high pressure supply hose(s), 3/8" compression connection(s)
- Bi-stable magnetic solenoid
- Four (4) "AA" alkaline batteries
- Double infrared sensors with automatic setting feature
- Single hole installation
- Includes all mounting hardware
- Line Purge mode, eliminates stagnant water
- Adjustable time-outs
- High temperature auto shut-off (LCD models)
- Faucet can be configured to add solar and/or LCD display
- LCD display of water temperature and scrub time (optional)
- Solar power harvesting options
- Line powered using a variety of voltage adapters (batteries act as back-up)
- Mechanical mixing, integral to spout, optional
- Thermostatic, below deck for ASSE 1070 compliance, optional



EFX-300.000.0000 Shown

BASYS Spec Language

Sloan BASYS Model No. EFX-300._____._____. Infrared Sensor Activated Electronic Handwashing Faucet for pre-tempered or hot/cold water supplies. Product to have double infrared sensors with automatic setting feature. Solenoid valve housed in removable carrier that closes water supply upon removal, eliminating need to access control stops. Solenoid carrier included for easy above deck service. Thermostatic mixer ordered separately to comply with ASSE 1070 requirements. The product shall be tested and certified to industry standards: ASME A112.18.1M, CSA B125.1, California Health and Safety Code 116875 (AB1953-2006), and Vermont Bill S.152. This product meets ADA ANSI/ICC A117.1 requirements.

Model Creation Guide

EFX-300. X 0 X . 0 X X 0 . X

	Mix	Sensing	Flow Rate	Battery Type	Base Plate	Voltage Adapters	Drain Pop-Up	Finishes
0	<input type="checkbox"/> None	Active IR	<input type="checkbox"/> 0.5 gpm Multi-Lam	Alkaline	<input type="checkbox"/> None	<input type="checkbox"/> None	No	<input type="checkbox"/> CP
1	<input type="checkbox"/> Below Deck, Mechanical	-	-	-	<input type="checkbox"/> 4"	<input type="checkbox"/> Plug-In	-	<input type="checkbox"/> PVDSF
2	<input type="checkbox"/> Below Deck, Thermostatic	-	<input type="checkbox"/> 1.5 gpm Aerated & Laminar	-	<input type="checkbox"/> 8"	<input type="checkbox"/> Plug-In UK	-	-
3	-	-	-	-	-	<input type="checkbox"/> Plug-In EU	-	-
4	-	-	-	-	-	<input type="checkbox"/> Box Mount	-	-
5	<input type="checkbox"/> Integral Side Mixer	-	-	-	-	-	-	-

Accessories (Ordered Separately)

- EAF-23 Splitter (included in hardware less adapter)
- EAF-24-A 11-13/16" Extension Cable
- EAF-25-A 47-1/4" Extension Cable
- EAF-17-A 126" Extension Cable

Warranty

3 year (limited)



This space for Architect/Engineer approval

Job Name	Date	Quantity
Model Specified		
Variations Specified		
Customer/Wholesaler		
Contractor		
Architect		

EFX-300-X0X-0XX0-X

Description

Battery powered, sensor activated, electronic, chrome plated die cast body, pedestal hand washing faucet for pre-tempered or hot and cold water operation.

Flow Rates

- 0.5 gpm/1.9 Lpm Multi-Lam Spray
- 1.5 gpm/5.7 Lpm Aerated Stream
- 1.5 gpm/5.7 Lpm Laminar Stream

ELECTRICAL SPECIFICATIONS

Control Circuit

6.75 VDC

Sensor Range

Nominal: 4"-5" (102 mm-127 mm)
Faucet Adaptive Self-Adjustment
Range: 1"-6" (25 mm-150 mm)

Battery Life

5-years under worst case conditions of 8,000 cycles per month and high water pressure. Optional power harvesting may extend service life of batteries to equal the shelf life.

Solenoid Valve

Filtered Solenoid Valve with Serviceable Strainer Filter

Power Supplies

- 6 VDC Solar Energy Module with 6 VDC Alkaline Battery Pack
- 120 VAC/6.75 VDC Voltage Adapter (Option) Batteries Act as Backup Shown with EFX-300.500.0000

Time Out Setting

30 seconds — Maximum time faucet will run upon continuous detection

Can combine up to six (6) faucets on one voltage adapter

DIMENSIONS

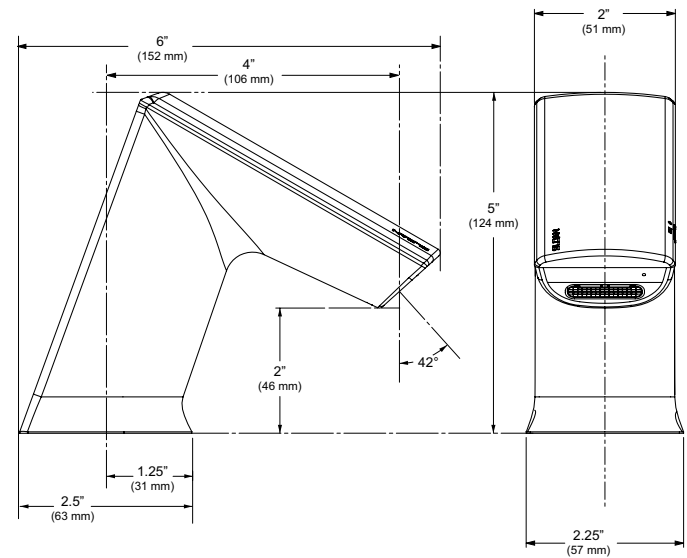

OPERATION

1. A continuous, invisible light beam is emitted from the sensor located at the front of the hand washing faucet.

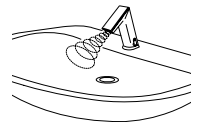

2. As the user's hands enter the beam's effective range, the beam is reflected back into the sensor receiver and activates the solenoid valve allowing water to flow from the faucet. Water will flow until the hands are no longer sensed or until the faucet reaches its automatic time out limit setting.

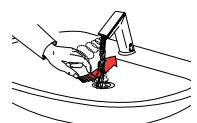

3. When hands are moved away from the sensor, the loss of reflected light initiates an electrical signal that closes the solenoid valve, shutting off the water flow. The circuit then automatically resets and is ready for the next user.

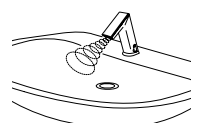

Electrical Connection for up to Six (6) Faucets Using One (1) Voltage Adapter

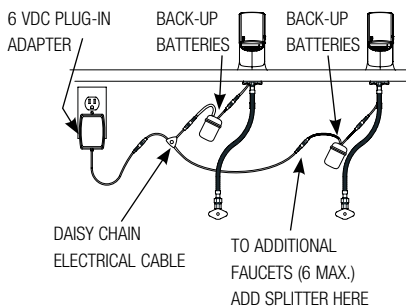

ROUGH-IN DIAGRAM

EFX-300.00X.001X

Faucet with Single Line Water Supply

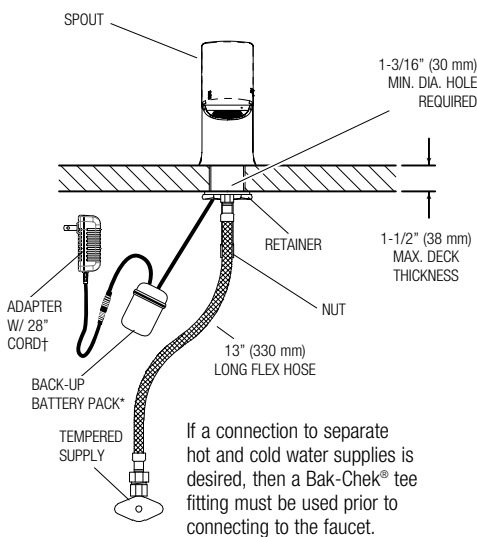

EFX-300.50X.001X

Faucet with Hot/Cold Water Supply

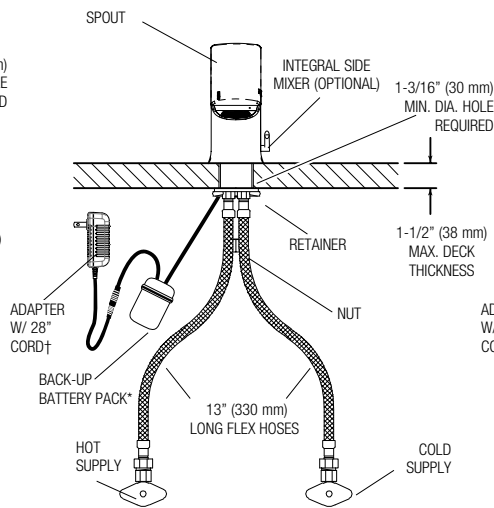

EFX-300.X0X.001X

Faucet with Hot/Cold Water Supply

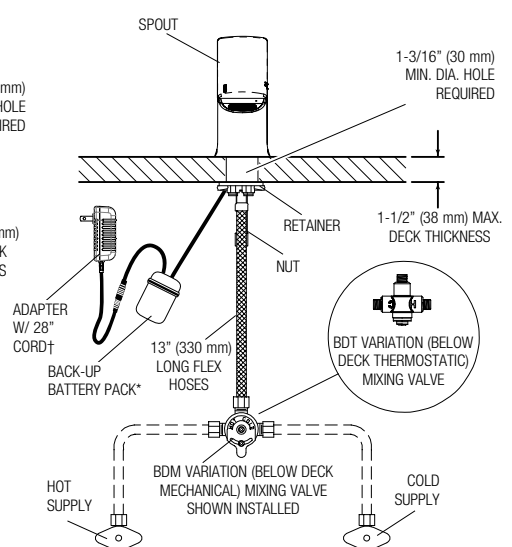

* One (1) Faucet Per Battery Pack

† Up to Six (6) Faucets on One (1) Voltage Adapter

When the EFX Series faucet is installed on a sink that has three (3) hole punchings, a Base Plate should be used.

Base Plates should be specified at time of order.

EFX-20-A - 4" Centerset

EFX-26-A - 8" Centerset

SLOAN HEADQUARTERS • 10500 SEYMOUR AVENUE • FRANKLIN PARK, IL 60131

Phone: 1-800-9-VALVE-9 or 1-847-671-4300 • Fax: 1-800-447-8329 or 1-847-671-4380 • www.sloanvalve.com